



**VINAYAK
INTERIORS**

TURNKEY PROJECT SOLUTION

PROFILE



INTERIORS & CONSTRUCTION
**CORPORATE
BANKING**
COMMERCIAL
FOOD CHAIN OUTLETS
RESIDENTIAL



**VINAYAK
INTERIORS**

TURNKEY PROJECT SOLUTION



ABOUT US :

We feel immense pleasure to introduce ourselves And our services. The founder of the company Mr. Mohan Sharma is in the field of interior refurbishment for the last 15 years.





THE PROCESS :

We always want a everlasting relationship with our clients. We always recommend our clients the best design and execution solutions. Money matters. We help our clients to save it by providing economical but outstanding and execution solutions.



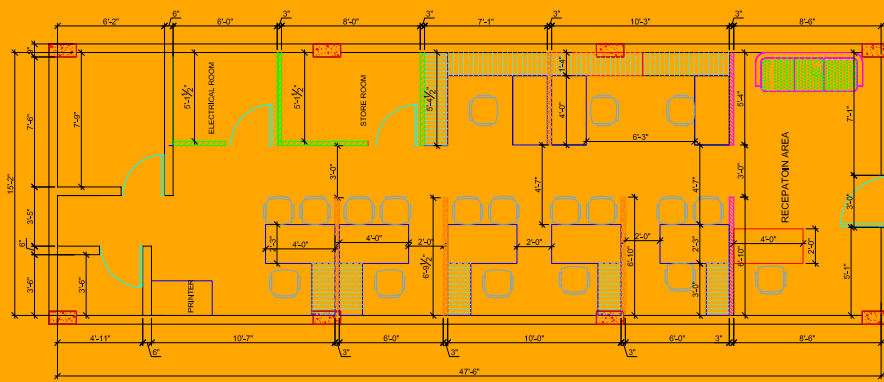

LEGEND SOLID PARTITION FULLY GLAZED PARTITION LOW HT. WITH GLASS ON ONE SIDE (L.O.S.) 2-4FT HIGH STORAGE LOW HT. WITH LAMINATE (L.P.L.) PROPOSED BRICK WORK 4-6FT HIGH STORAGE PARTLY GLAZED PARTITION (BOTH SIDES LAMINATE) GYPSUM PARTITION	
TOTAL CARPET AREA= 717 sqft	
S.No.	
Project SHRIRAM CAPITAL DEHRADUN	
Drawing title LAYOUT PLAN	
project no.	
drawn	VINAYAK INTERIORS
date	9/12/2014
Designers Vinayak Interiors B-12/105, SHALABAG GARDEN EXT. 2, SAHIBNAG CHAKRAHAT CLP, ETOH-40, Dehradun/India@gmail.com mobile: 921237917/9898111275	

PROJECT TEAM :

We are having a strong team of qualified supervisors and skilled worker in the various disciplines. Personal involvement of our director and the indirect interaction in each project enables us to complete the projects with stringent standards of quality workmanship within specified time schedule.

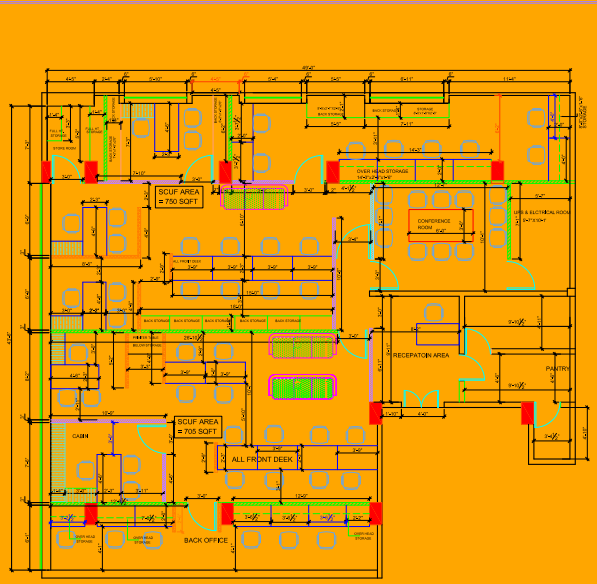

LEGEND SOLID PARTITION FULLY GLAZED PARTITION LOW HT. WITH GLASS ON ONE SIDE (L.O.S.) 2-4FT HIGH STORAGE LOW HT. WITH LAMINATE (L.P.L.) PROPOSED BRICK WORK 4-6FT HIGH STORAGE PARTLY GLAZED PARTITION (BOTH SIDES LAMINATE) GYPSUM PARTITION	
SCUF-EL AREA = 750 sqft SVRCL AREA = 710 sqft CONFERENCE ROOM #125 sqft COMMON AREA = 350 sqft	
S.No.	
Project SHRIRAM CAPITAL INDORE (MP)	
Drawing title LAYOUT PLAN	
project no.	
drawn	VINAYAK INTERIORS
date	9/12/2014
Designers Vinayak Interiors B-12/105, SHALABAG GARDEN EXT. 2, SAHIBNAG CHAKRAHAT CLP, ETOH-40, Dehradun/India@gmail.com mobile: 921237917/9898111275	

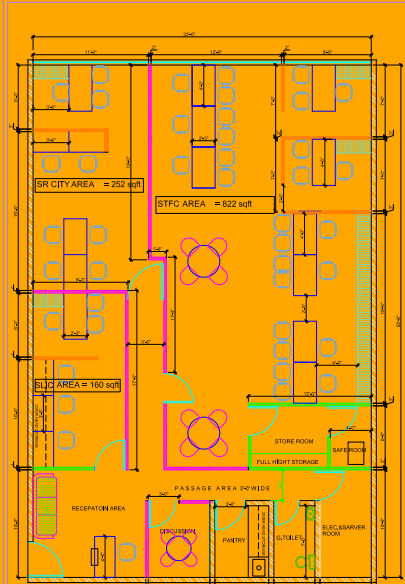

LEGEND SOLID PARTITION FULLY GLAZED PARTITION LOW HT. WITH GLASS ON ONE SIDE (L.O.S.) 2-4FT HIGH STORAGE LOW HT. WITH LAMINATE (L.P.L.) PROPOSED BRICK WORK 4-6FT HIGH STORAGE PARTLY GLAZED PARTITION (BOTH SIDES LAMINATE) GYPSUM PARTITION	
TOTAL CARPET AREA = 1650 SQ.FT.	
S.No.	
Project SHRIRAM CAPITAL BANDA UP	
Drawing title LAYOUT PLAN	
project no.	
drawn	VINAYAK INTERIORS
date	13/11/2014
Designers Vinayak Interiors B-12/105, SHALABAG GARDEN EXT. 2, SAHIBNAG CHAKRAHAT CLP, ETOH-40, Dehradun/India@gmail.com mobile: 921237917/9898111275	

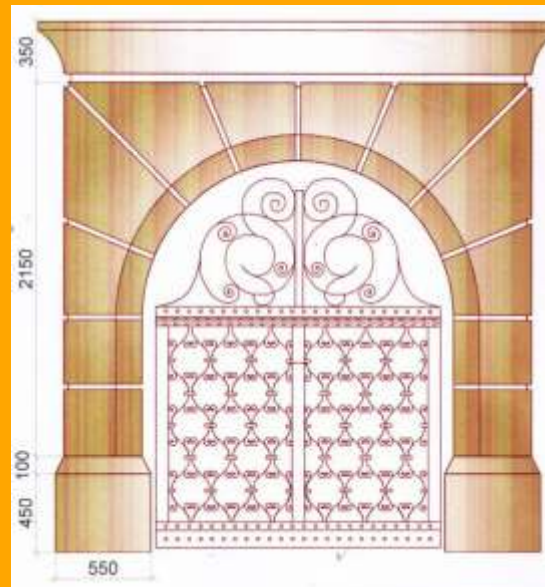
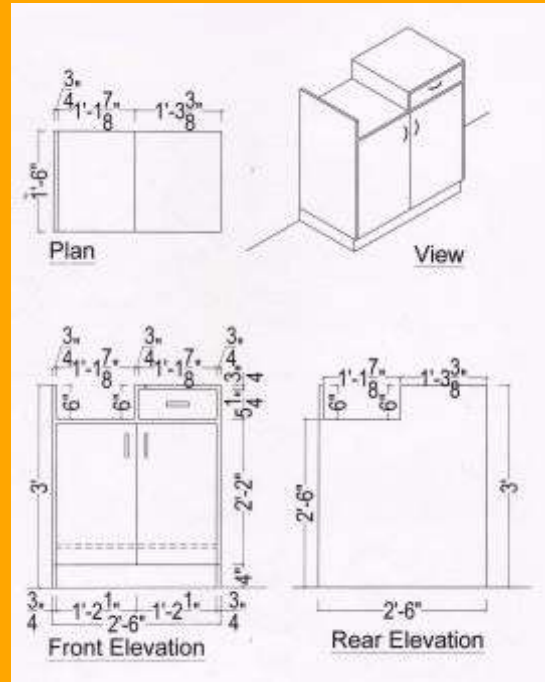
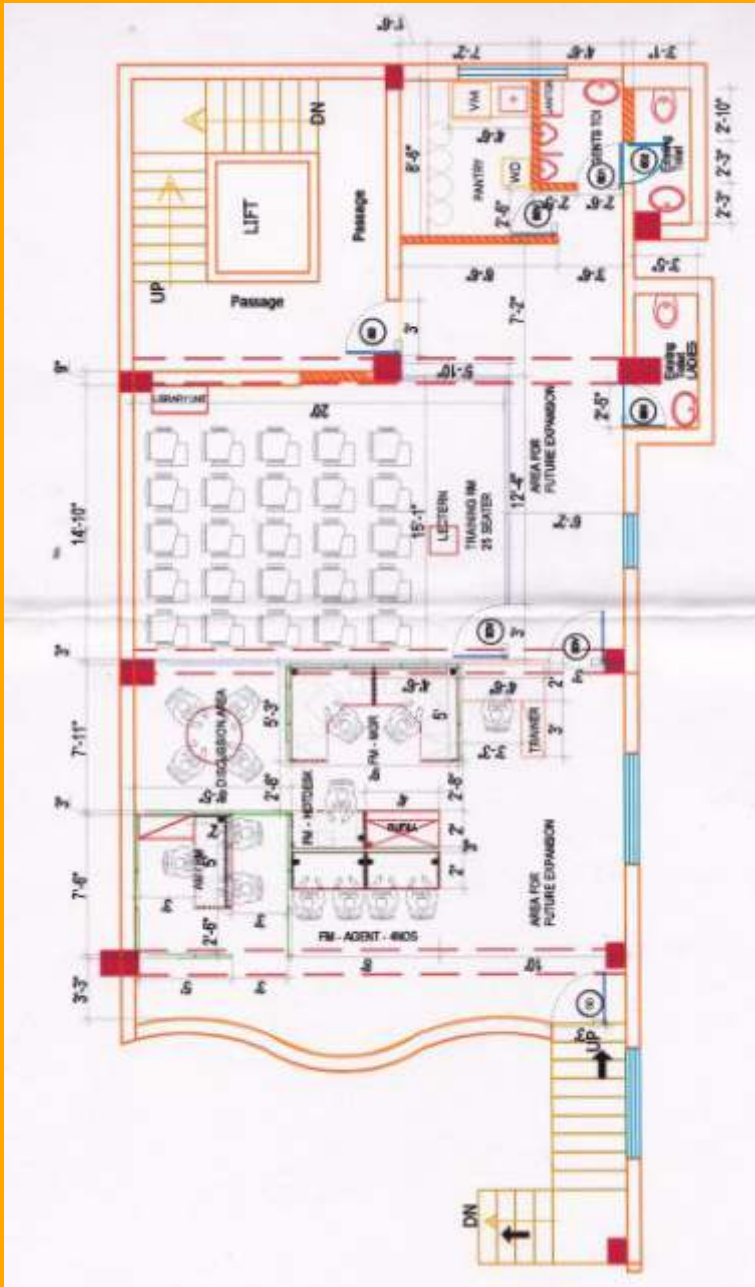

**VINAYAK
INTERIORS**

TURNKEY PROJECT SOLUTION



**VINAYAK
INTERIORS**

TURNKEY PROJECT SOLUTION



TIME SCHEDULE :

Time is precious. We define a time schedule to complete a project with necessary steps. Our planning of execution is time saving and cost effective.

TYPES OF PROJECTS :

VINAYAK Interior is completely involved in design and execution of interior of residence, commercial and corporate houses. A client can have a better idea with us how to design his house or how to get corporate ambience in to his office. We are up to date with all kind of modern facilities available in the market which is widely used for interior fit-out. Simply, it is with in one roof, all the solution...



PROJECTS DETAIL :-

Working under the Geographic's interiors.

RELIANCE GENERAL INSURANCE

RELIANCE COMMUNICATIONS

TATA AIG

STREET FOOD OF INDIA



Mc'DONALDS

HDFC BANK

ICICI BANK

MAX NEW YORK LIFE INSURANCE

CDBS CHOLA MANDLAM

CITI FINANCIAL



FRESCO RESTAURANT

AVIVA LIFE INSURANCE

DCDL

BHARTI RETAIL

AXIS BANK



PHOTO GALLERY

Completed Projects

Ongoing Projects

Proposals



PROJECT IMAGES :



PROJECT IMAGES :

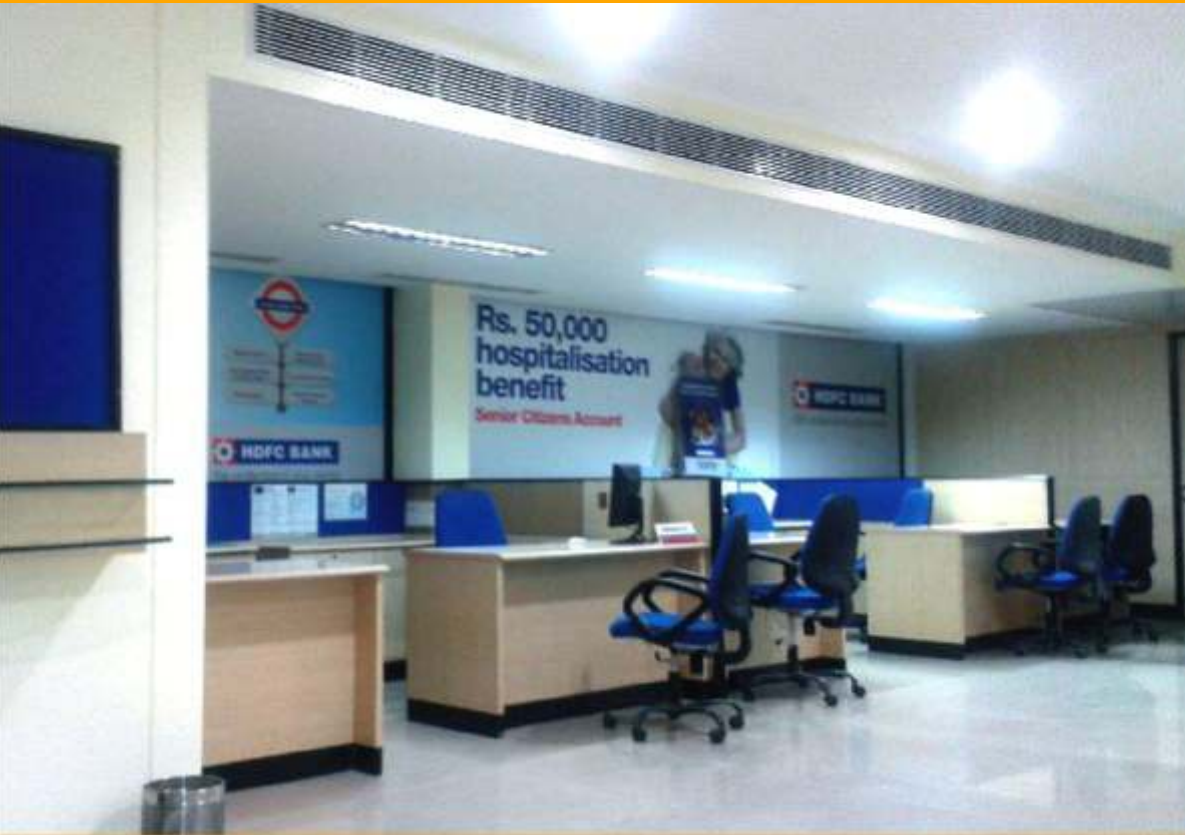

**VINAYAK
INTERIORS**

TURNKEY PROJECT SOLUTION



PROJECT IMAGES :



**VINAYAK
INTERIORS**

TURNKEY PROJECT SOLUTION

PROJECT IMAGES :



PROJECT IMAGES :



PROJECT IMAGES :

Ongoing Projects

Ludhiana

Indore

Dehradun

Chandigarh

Jalandhar

Banda



**VINAYAK
INTERIORS**

TURNKEY PROJECT SOLUTION







Thank you...

VINAYAK INTERIORS

B-123/b-5, Shalimar Garden, Extn II, Sahibabad, Ghaziabad (up)
Contact : +91 9212376797, 9716045750 E-mail : vinayakinteriors07@gmail.com